

PCU-X11 WirelessHART Inclinometer

Description

Syscor's PCU-X11 WirelessHART Inclinometer was developed and qualified, in close cooperation with the petroleum industry, to detect and measure inclination and acceleration changes using a high reliability, MEMS sensor. The Intrinsically Safe PCU-X11 can also provide power and communication to optional sensor probes.

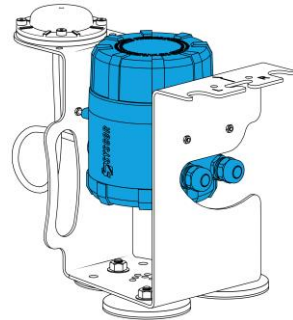

Figure 1. Inclinometer using a floating roof mounting bracket with magnetic feet

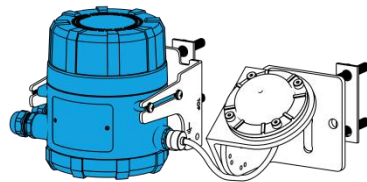

Figure 2. Inclinometer using 2" pole U-bolt

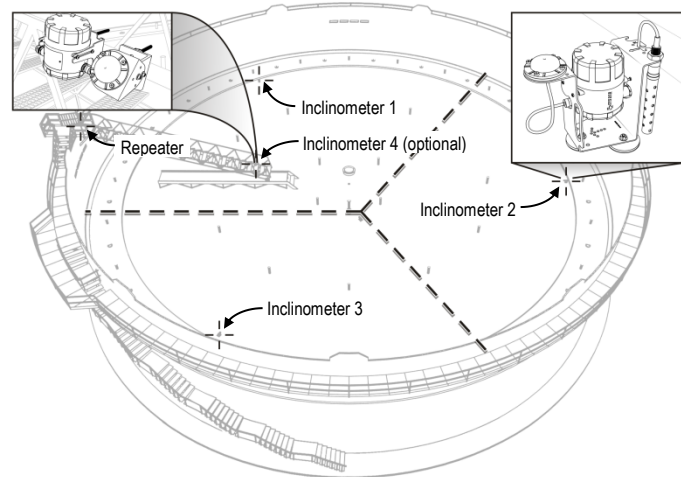

Figure 3. Typical Inclinometer setup for monitoring storage tank floating roofs

Applications

The solution targets tank floating roofs, ladders, and other stability applications. Deck hydrocarbon detection (butane and heavier) and water level measurement are provided by optional sensor probes.

Power

The Inclinometer is powered by Syscor's 902 Battery Pack that contains high energy density lithium thionyl chloride (Li-SOCl₂) cells. Low self-discharge provides 10+ years of reliable and predictable power, depending on the update rate.

Installation

The Inclinometer can attach directly to equipment or structures with Syscor's Universal or Floating Roof Mounting Brackets. No hot work is required. Optional bracket magnets can be used on flat steel surfaces, such as steel floating roofs.

WirelessHART Communication

The Inclinometer utilizes the industry standard WirelessHART protocol, which accounts for roughly 30% of the industrial wireless sensing market.* Data is transmitted from the WirelessHART Gateway to the facility's DCS/SCADA using standard industrial interfaces and protocols. WirelessHART (IEC 62591) is a secure, full mesh technology capable of self-forming, healing, and scaling.

* <https://www.controlglobal.com/articles/2019/arc-report-details-growth-of-fspan-stylefont-size-x-smallfoundationspan-fieldbus-hart-and-emwirelessemhart/>

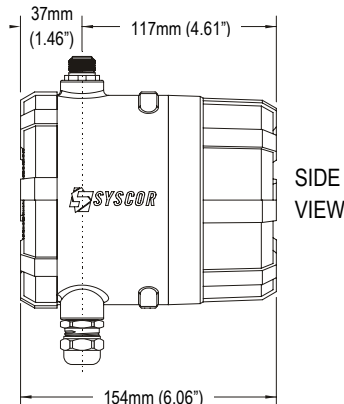
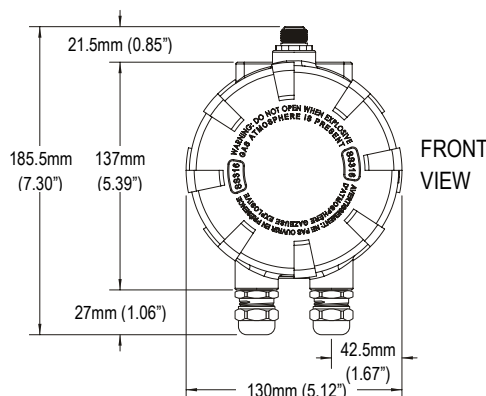

Specifications

Functional Specifications

Internal Sensors	Inclinometer, vibration/accelerometer, electronics temperature
External Sensors	Syscor's HCD and HCDW Probes connect directly to the PCU-X11 Inclinometer via 1/2in. NPT ports or can be mounted remotely with cable. If two sensor probes are used, total combined cable length for Intrinsically Safe operation cannot exceed 10m (33ft.).
Wireless.	WirelessHART IEC 62591 2.4 GHz DSSS
Wireless Data Update Rate	User-selectable; 5 seconds to 1 hour
Power Supply (Battery Pack)	Model 902 Battery Pack: 4-cell, 7.2V 38.0Ah 273.6Wh Battery pack is Li-SOCl ₂ , field replaceable, Intrinsically Safe, and has 10+ years of battery life depending on application and update rate.
Communication	Maintenance Port for communication with HART field communicator

Physical Specifications

Enclosure	Stainless steel SS316. IP67, Type 4X Optional sensor probes are IP68, Type 4X
Antenna Port	N-Type female
Sensor Probe Ports	1/2in. NPT
Sensor Wiring Connections	Screw terminals
Weight	3.75kg [8.3lbs.]
Mounting Options	<ul style="list-style-type: none"> - Floating Roof Mounting Bracket with magnets (see Fig. 1) - Universal Mounting Bracket with 2" or 5" U-bolt (see Fig. 2)

Performance Specifications

Inclination	Dual-axis, horizontal operation, ±90° High accuracy, 0.1° Digital inclination data, 0.025° resolution
Vibration and Acceleration	Ultra-low-power, high performance, three-axis linear accelerometer; Dynamically selectable range from 0g to 16g; Acceleration and velocity detection
Electronics Temperature	Integrated circuit sensing elements embedded inside, provide up to +/- 1°C [1.8°F]
Operating Temp.	-40°C to +60°C [-40°F to +140°F]

Certifications

USA	FCC: 2AAZE-000697 Intrinsic Safety: CSA 19CA70174889X Class I, Division 1, Groups C and D, T4 Class I, Zone 0 AEx ia IIB T4 Ga
Canada	IC: 11413A-000697 Intrinsic Safety: CSA 19CA70174889X Class I, Division 1, Groups C and D, T4 Ex ia IIB T4 Ga
Europe	Intrinsic Safety: SIRA 18ATEX2249X Ex ia IIB T4 Ga CE ₂₈₁₃
IECEX	Intrinsic Safety: IECEX CSA 18.0031X Ex ia IIB T4 Ga

Learn More

HCD Hydrocarbon Detector Probe	syscor.com/downloads/syscor_spec-sheet_hcd-probe_en_80169.pdf
HCDW Hydrocarbon Detector Probe with Water Level	syscor.com/downloads/syscor_spec-sheet_hcdw-probe_en_80171.pdf
Field Transmitter Battery Packs	syscor.com/downloads/syscor_spec-sheet_field-transmitter-battery-packs_en_80155.pdf
Floating Roof Bracket	syscor.com/products/antennas
Universal Mounting Bracket	syscor.com/technology/pas
Antennas	syscor.com/products/antennas